

ÜRÜN RESMİ / PRODUCT IMAGE



ÜRÜN DETAYI / PRODUCT DETAILS

12 V		
Kod / Part Number	612 106 13	
Gerilim / Voltage	12 VDC	
Kademe / Speed Level	I	II
Akım / Nominal Current	3,1 A	5 A
Güç / Power	15 W	45 W
Devir / Nominal Speed	3400 rpm	3900 rpm
Tork / Continuous Torque	13 Ncm	
Kilitleme Torkü / Breakaway Torque	55 Ncm	
Dönüş Yönü / Direction of Rotation	CW	
Çalışma Sınıfı / Type Of Duty	S1	
Koruma Der. / Degree Of Protection	IP22	
Ağırlık / Weight	0,792 kg.	

DRAWING

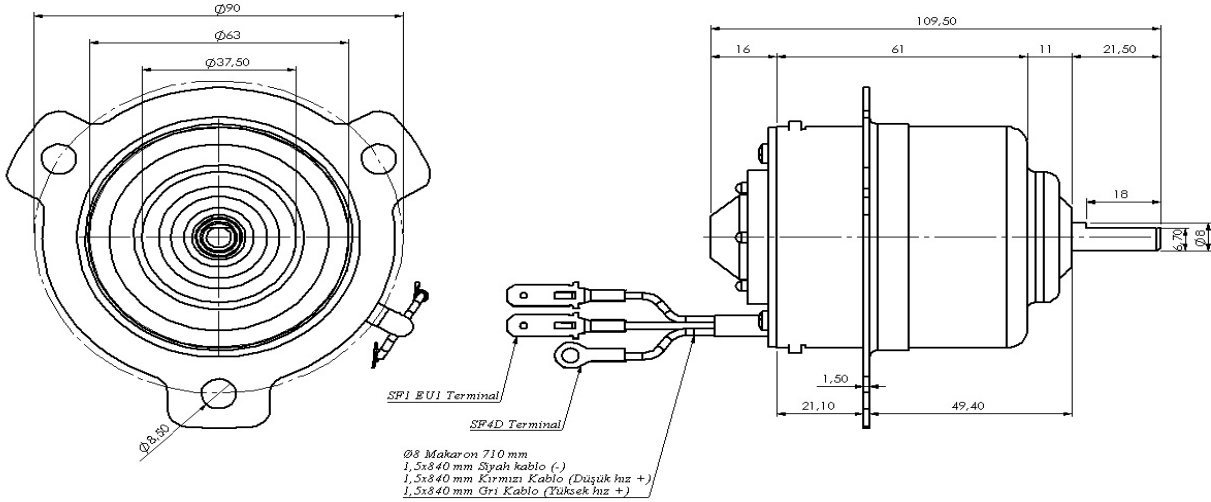

Akdeniz Caddesi G.49 Sok.No:29
Ferhatpaşa / Samandıra / Kartal / İstanbul
Tel : 90 216 660 10 11 - Fax: 90 216 660 10 44
info@kormas.com