

ÜRÜN RESMİ / PRODUCT IMAGE



ÜRÜN DETAYI / PRODUCT DETAILS

	12 V	
Kod / Part Number	622 133 05	
Gerilim / Voltage	12 VDC	
Kademe / Speed Level	I	II
Akım / Nominal Current	3,2 A	5,5 A
Güç / Power	10 W	40 W
Devir / Nominal Speed	3000 rpm	3600 rpm
Tork / Continuous Torque	12 Ncm	
Kilitleme Torkü / Breakaway Torque	57 Ncm	
Dönüş Yönü / Direction of Rotation	CW	
Çalışma Sınıfı / Type Of Duty	S1	
Koruma Der. / Degree Of Protection	IP22	
Ağırlık / Weight	0,940 kg.	

DRAWING

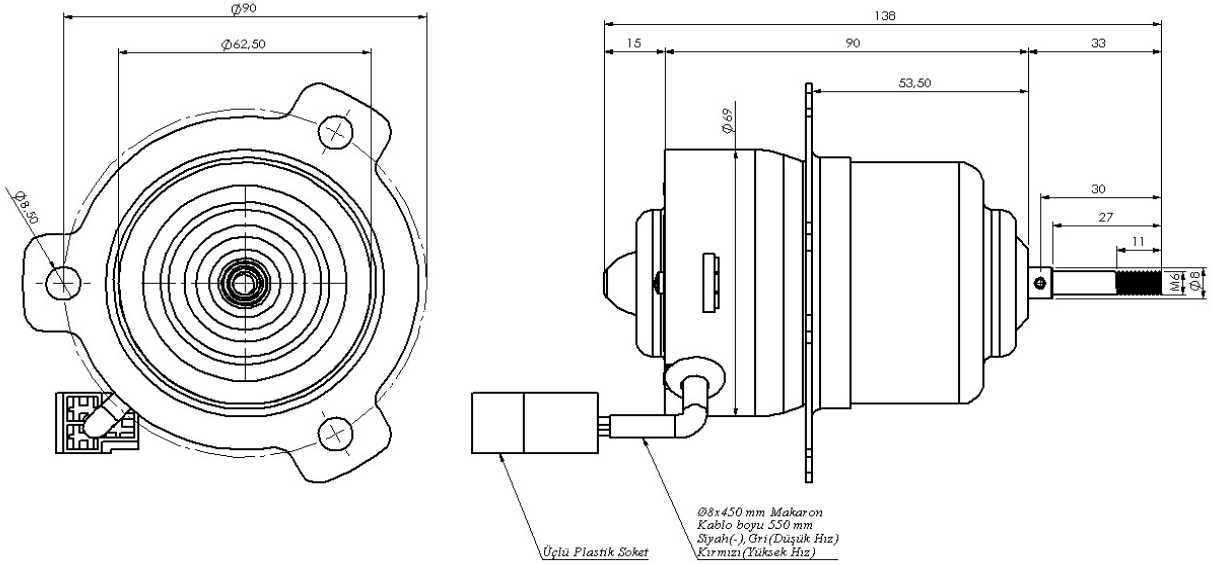

Akdeniz Caddesi G.49 Sok.No:29
Ferhatpaşa / Samandıra / Kartal / İstanbul
Tel : 90 216 660 10 11 - Fax: 90 216 660 10 44
info@kormas.com